

Intelligent Drivesystems, Worldwide Services

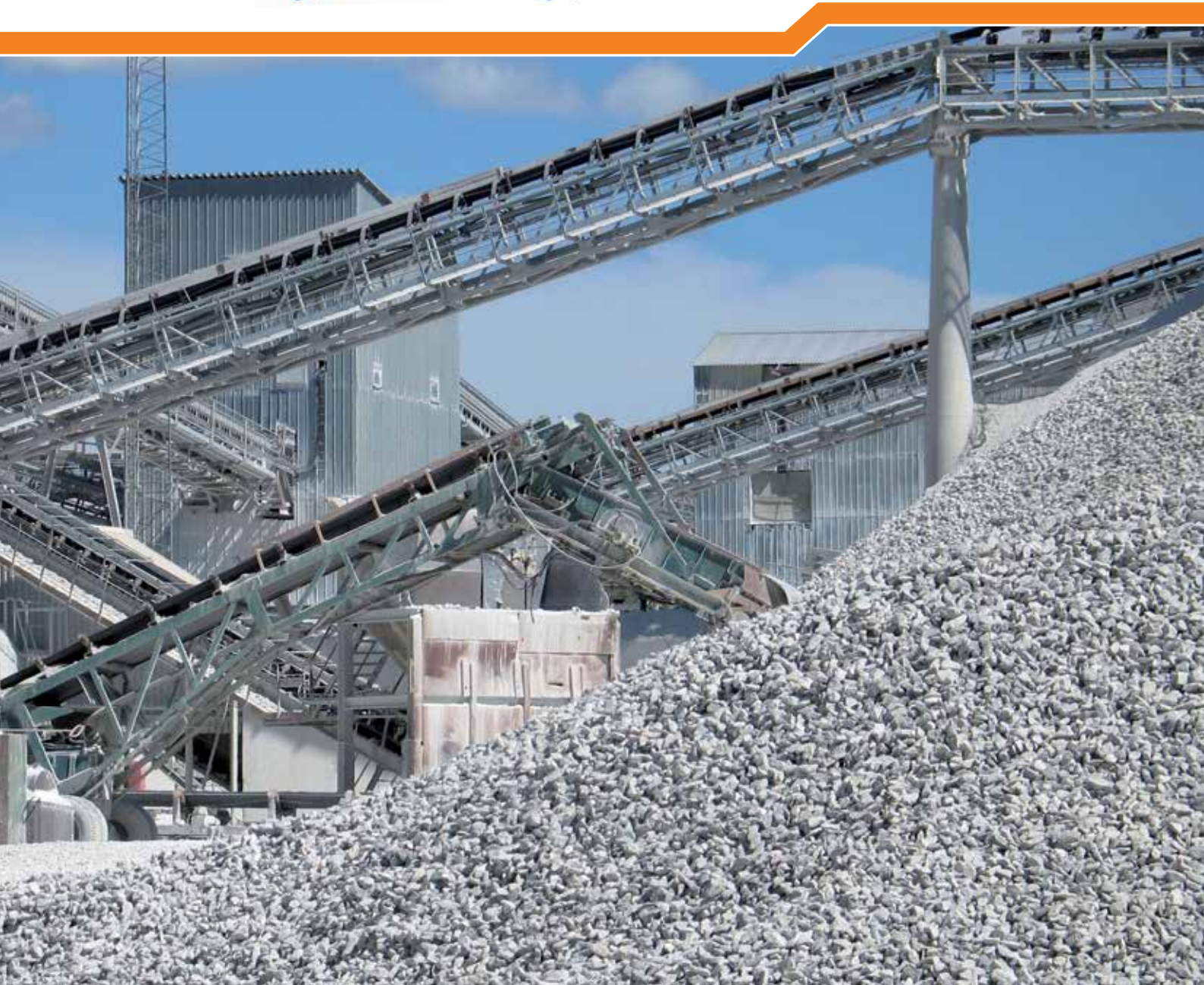
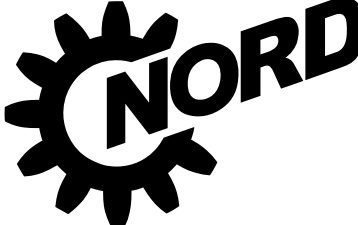

EN

**Drive solutions for the  
cement industry**

  
**DRIVESYSTEMS**



# Partners in motion

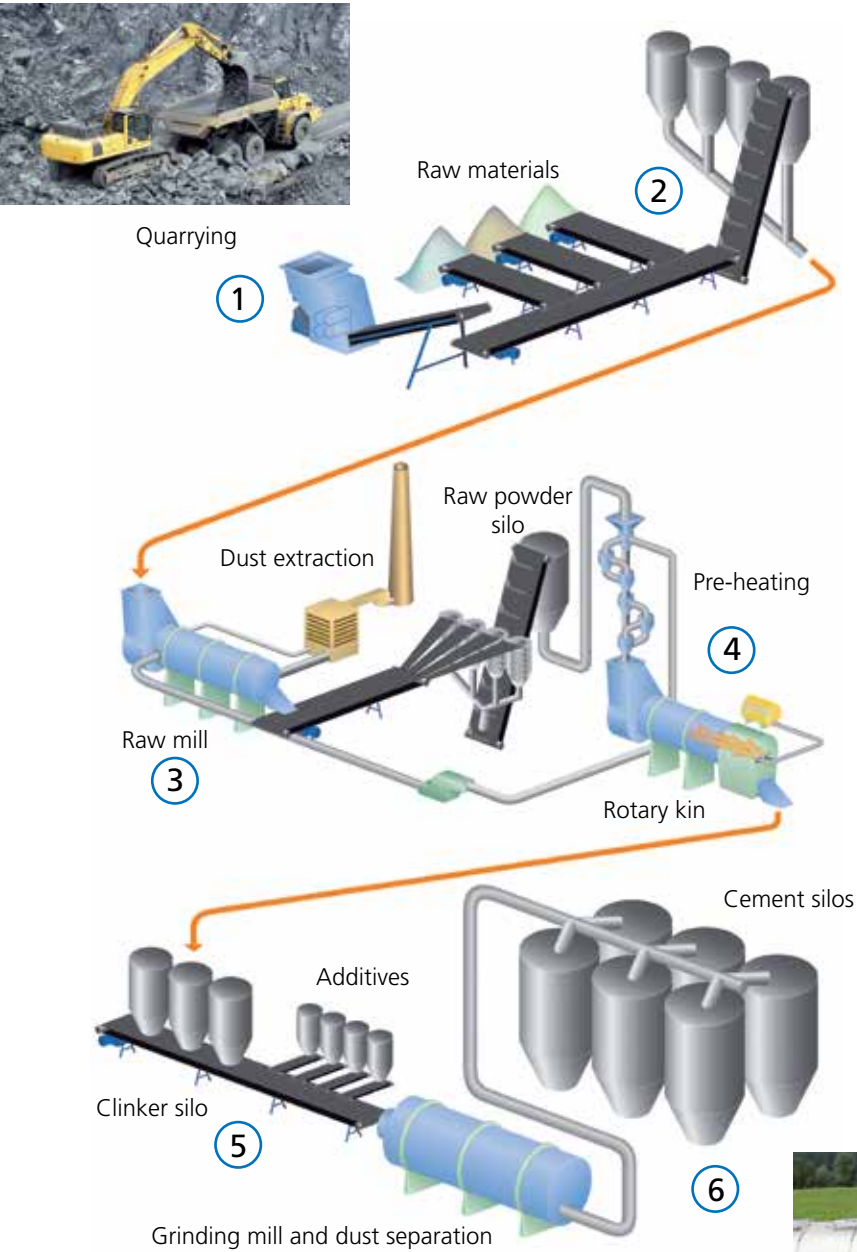

## Efficient drive solutions for the cement industry

Cement based materials are essential for sustainable building. However, cement manufacture is a sophisticated process whose individual stages require a great deal of energy. This makes energy costs one of the largest cost factors for the industry. Because of this, cement production requires drive units which can stand up to harsh conditions and are also especially energy-efficient.

For more than 45 years, NORD DRIVESYSTEMS has been at home in almost every branch of industry where conveying solutions are used. Our drive components and systems are essential wherever things need to be moved, because all movement needs drive - as efficiently and safely as possible. Because of this, we provide an entire spectrum of mechanical, electrical and electronic drive technology from a single source - from energy-efficient motors and low-loss gear units to centralised and decentralised control technology.



Transport



DRIVESYSTEMS



**NORD DRIVESYSTEMS:**

- Highest standards of technology and quality
- Comprehensive advice on systems and products
- High availability and rapid service throughout the world



- 1 **Slat conveyor** (Industrial gear unit AS version, SK 12407 -13407)
- 2 **Chain excavator, transport drive unit, belt conveyor** (Industrial gear unit SK 11307 - 12307 / 12407 - 13407)
- 3 **Chain conveyor, grinding mill** (Industrial gear unit SK 11407 -13407)
- 4 **Rotary kiln drive, auxiliary drive** (Industrial gear unit, bevel gear unit SK 13207 - 15207 / SK 9072.1 - 9092.1)
- 5 **Container emptying, belt conveyor** (Industrial gear unit SK 11307)
- 6 **Silo emptying** (Industrial gear unit SK 11307)



# Perfect for harsh environments

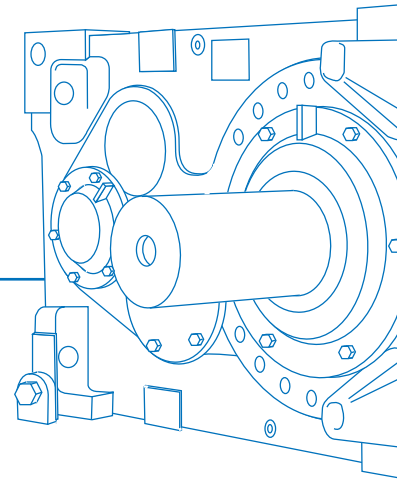

## Tailor made configurations

All NORD drive solutions are configured using the NORD function pyramid principle. With all the options and modules that are available, it is easy to plan and implement solutions for special requirements. Standardisation of drive components guarantees quality and ensures rapid availability for our customers.

For short and long distance conveyor systems, mill and rotary kiln drives, as well as silo operation, NORD DRIVESYSTEMS provides the very latest, energy-efficient drive solutions for every process stage in the cement industry. NORD industrial gear units can master any challenge. NORD DRIVESYSTEMS plans and delivers reliable, low maintenance drive components for the entire drive chain, including electric motors, motor rockers, couplings, brakes, back stops and Taconite seals as well as heating and/or cooling.



Left: NORD drive unit on a bucket wheel excavator,  
Right: Rotary kiln in a cement works



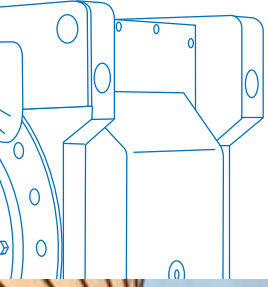

The selection of the right components for the optimisation of internal processes is decisive for the efficiency and safety of your transportation systems. High quality products, innovative technology and the world-wide presence of NORD DRIVESYSTEMS guarantee a high level of customer satisfaction.

# Low-loss UNICASE gear units



Helical gear unit		
<ul style="list-style-type: none"> <li>✓ Foot or flange-mounted versions</li> <li>✓ UNICASE housing</li> </ul>	Sizes	11
	kW	0.12 – 160
	Nm	23 – 23,160
	i	1.24 : 1 – 14,340.31 : 1



NORDBLOC. 1 gear unit		
<ul style="list-style-type: none"> <li>✓ Foot or flange-mounted versions</li> <li>✓ Die-cast aluminium housing (5 sizes)</li> <li>✓ UNICASE housing</li> <li>✓ Dimensions according to industry standard</li> </ul>	Sizes	8
	kW	0.12 – 37
	Nm	55 – 3,300
	i	2.10 : 1 – 456.77 : 1



Parallel shaft gear units		
<ul style="list-style-type: none"> <li>✓ Shaft mounted, foot or flange-mounted</li> <li>✓ Hollow or solid shaft</li> <li>✓ Compact design</li> <li>✓ UNICASE</li> </ul>	Sizes	15
	kW	0,12 – 200
	Nm	65 – 90.000
	i	4,03 : 1 – 6.616,79 : 1



3-stage Bevel gear units		
<ul style="list-style-type: none"> <li>✓ Up to 95 % efficiency</li> <li>✓ Shaft mounted, foot or flange-mounted</li> <li>✓ Hollow or solid shaft</li> <li>✓ UNICASE</li> </ul>	Sizes	11
	kW	0,12 – 200
	Nm	180 – 50.000
	i	8,04 : 1 – 13.432,68 : 1



Industrial Gear Units		
<ul style="list-style-type: none"> <li>✓ Parallel shaft and bevel gear versions</li> <li>✓ UNICASE design</li> <li>✓ Temperature management</li> </ul>	Sizes	8
	kW	2,2 – 1.000
	kNm	25/30/40/50/70/101/141/242
<ul style="list-style-type: none"> <li>✓ Wide selection of sensor options</li> <li>✓ Wide selection of sealing options</li> </ul>	i	5,54 : 1 – 1.600,00 : 1



DRIVESYSTEMS

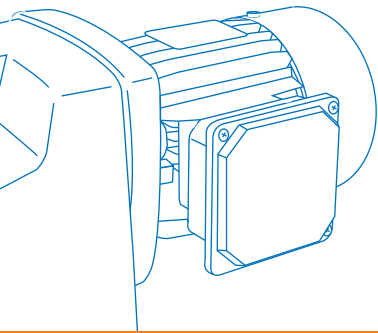

### The UNICASE concept

A closed housing manufactured from a single block combines all the elements of the gear unit.

NORD is the only manufacturer which produces modular industrial gear units with an output torque of 242,000 Nm in a one-piece UNICASE housing.

- A single housing which integrates all gearbox components
- Complete machining in one step
- High output torque capabilities
- High axial and radial loads
- Great reliability
- Long service life
- Quiet running

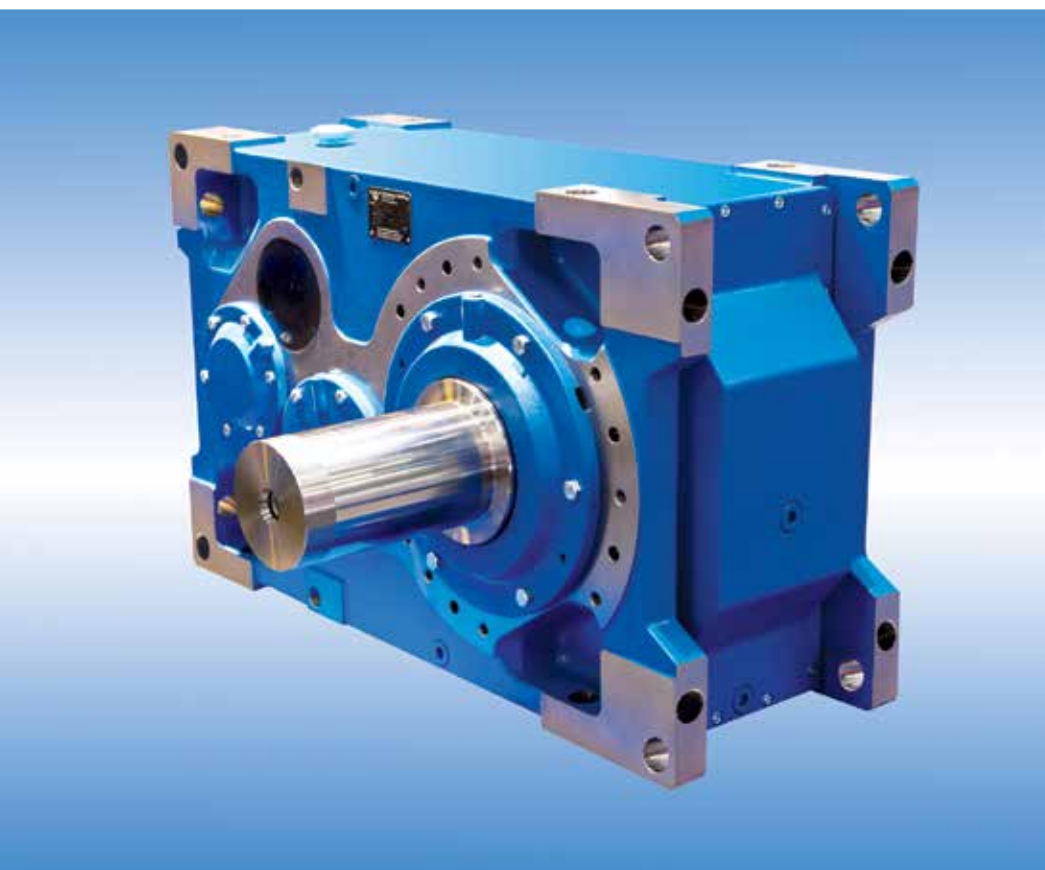

# Frequency inverters with energy-saving functions

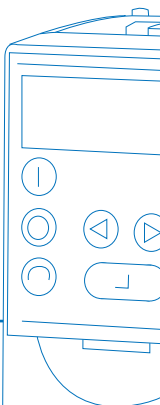

SK 500E		
<ul style="list-style-type: none"> <li>✓ Compact design</li> <li>✓ Energy saving function</li> <li>✓ Performance grading according to application (e. g. "Posicon" positioning control)</li> <li>✓ Push-on modules for control and communication (field bus)</li> <li>✓ Ethernet-based BUS systems</li> </ul>	Sizes	10
	U(V)	1 - 110 ... 120 ±10 % 1/3 - 200 ... 240 ±10 % 3 - 200 ... 240 ±10 % 3 - 380 ... 480 -20 % / +10 %
	P(kW)	0,25 - 90



SK 200E		
<ul style="list-style-type: none"> <li>✓ "Safe stop" as per EN 954-1</li> <li>✓ Commissioning via integrated DIP switches and potentiometer possible</li> <li>✓ Energy saving function</li> <li>✓ Ethernet-based BUS systems</li> <li>✓ Performance grading according to application</li> <li>✓ Decentralised modules combined as a system</li> <li>✓ Integrated "Posicon" positioning control</li> <li>✓ On board AS interface</li> </ul>	Sizes	4
	U(V)	1 - 100 ... 120 ±10 % 1 - 200 ... 240 ±10 % 3 - 200 ... 240 ±10 % 3 - 380 ... 500 -20 % / +10 %
	P(kW)	0,25 - 22

## Efficiency-optimised motors



IE2/IE3 motors
<p>NORD builds energy-saving three-phase motors both with and without brakes for the international market. Our own motor production facilities guarantee that NORD is independent from supply bottlenecks and can guarantee short delivery times. This is a decisive benefit to our customers. The use of NORD energy-saving three-phase motors with considerably higher efficiencies allows you to reduce operating costs. NORD energy-saving three-phase motors, compliant with the US Energy Policy Act of 1992 (EPA), are also available.</p>

You can find more information about NORD energy-saving motors and the new EU laws which came into force in June 2011 under [www.nord.com/IE2](http://www.nord.com/IE2).



DRIVESYSTEMS



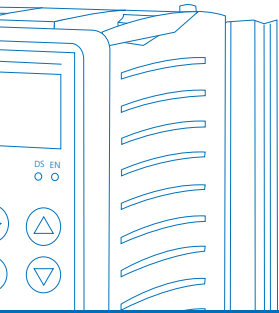

From the very beginning, for NORD DRIVESYSTEMS the decision for energy-saving drive units was not only an economic, but also an ecological one. For this, we rely on extremely energy-efficient motors, almost loss-free gear units and drive electronics with energy-saving functions - because using less energy means less environmental pollution.



### SK 500E

With frequency inverters from the SK 500E series, NORD DRIVESYSTEMS provides intelligent and economical drive solutions in graded configuration version, which are fully compatible with regard to power range, connection voltage and size.



### SK 200E

SK 200E inverters are available with almost the same functions as the SK 500E models. The spectrum of applications ranges from simple drive functions to complex positioning control.

Links to automation systems



Ethernet-based BUS systems



# Intelligent drive systems from a single source

NORD DRIVESYSTEMS drive solutions are based on the principle of the function pyramid: Motors, control units and gears are just as much components as our extensive range of system modules such as planning, project management, installation and service.

NORD DRIVESYSTEMS produces helical, parallel shaft, bevel gear and worm gear units and is the only manufacturer in the world which produces industrial gear units up to 242 kNm as unicas versions. The benefits for our customers include extreme reliability and exceptional sealing, safe handling of even the largest output torques, high axial and radial load bearing, quiet running and low maintenance and especially long operating life. With its own gear and motor production facilities, NORD offers its customers complete, sophisticated system solutions with the very highest levels of economy and efficiency.





Left: NORD DRIVESYSTEMS headquarters in Bargteheide, from top: Production plant in Gadebusch, Glinde, Aurich (all in Germany) motor factory in San Giovanni (Italy), production in Waunakee (USA), production in Suzhou (China)



### Always near you throughout the world

For globalisation, we rely on local roots. We have set up a network of assembly factories and service facilities in 35 of the most important industrialised countries, so that local planning advice, high availability of the required drive technology and rapid local service make NORD DRIVESYSTEMS a flexible and dependable partner for drive systems throughout the world.

- Close to customers thanks to 35 subsidiaries and more than 30 agencies throughout the world
- High availability and rapid service thanks to local presence
- Certification: ISO 9001, UL, CSA, GHOST-R, CCC and ATEX
- Everything from one source, from planning to commissioning
- You can find further up-to-the-minute data and facts about NORD DRIVESYSTEMS under [www.nord.com](http://www.nord.com)





[www.nord.com/locator](http://www.nord.com/locator)

**Headquarters:**

**Getriebebau NORD GmbH & Co. KG**

Getriebebau-Nord-Straße 1

22941 Bargteheide, Germany

Fon +49 (0) 4532 / 289-0

Fax +49 (0) 4532 / 289-2253

info@nord.com, www.nord.com

**Member of the NORD DRIVESYSTEMS Group**

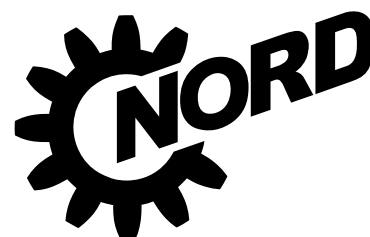

**DRIVESYSTEMS**